

Manufactured by:
Visual Lighting Technologies
1809 Hur Industrial Blvd.
Cedar Park, TX 78613
Phone: (877) VLT-1167
www.VLTCorp.com



EssentialLEDs Linear – Installation Instructions

**WARNING: FIXTURES TO BE INSTALLED WITH EITHER
CLASS 2 POWER UNIT FROM CHART PROVIDED BELOW.**

**INSTALLATION OR USE OF FIXTURES WITH OTHER THAN THE UNITS LISTED MAY CAUSE
ELECTRICAL SHOCK, FIRE OR PERMANENT PRODUCT DAMAGE.**

*This Product Must Be Installed in Accordance with the Applicable Installation Code by a
Person Familiar with the Construction and Operation of the Product and the Hazards Involved.*

Each piece of EssentialLEDs Linear LEDs is factory labeled with the total wattage for each piece.

EssentialLEDs linear products must be installed using LED drivers specifically designed for use with LED products, per product warranty. Visual Lighting Technologies offers a variety of LED drivers for use with EssentialLEDs Linear products, ranging from 10w to 96w. Depending on the size and configuration of your application, one or more drivers will be supplied with your order. Size and number of drivers needed will be determined by the configuration of your application, which has been designed to use the drivers as efficiently as possible.

Where applicable, multiple pieces of EssentialLEDs Linear can be daisy-chained and connected to a single driver, **NOT TO EXCEED 88 WATTS IN A SINGLE RUN, and as long as the wattage total does not exceed the capacity of the driver used.**

Select the correct Class 2 Power Unit (LED driver) from chart provided on page 7

General Notes Re: Installation of EssentialLEDs Linear

- EssentialLEDs Linear products are suitable for surface or recessed installation.
- EssentialLEDs are shipped in appropriate packaging, including plastic sleeves. To prevent damage or scratching, products should remain in packaging until installation.
- Due to its slim form, the EssentialLEDs 1S (small square) extrusion bends easily; **CARE MUST BE TAKEN TO AVOID BENDING THE EXTRUSION DURING INSTALLATION.** All pieces of 1S extrusion over 30" in length are shipped with a support backing to prevent bending during shipment. **DURING INSTALLATION, PRODUCT MUST BE HANDLED WITH CARE;** whenever possible, move lengths directly from support backing into clips on mounting surface.
- Before beginning installation, study the layout and circuit structure as specified in the application plans and insure that each circuit is assigned to an appropriately-sized driver. Using drivers or power supplies other than those supplied by VLT will **VOID PRODUCT WARRANTY.**

- For **any single piece** or **any combined pieces** of EssentialLEDs, if total wattage exceeds driver capacity by even a small amount, **the next size driver must be used!** (i.e. 42 LEDs x .25w = 10.5 watts: **Must Use 25w 24v Driver!**)
- Before connecting EssentialLEDs to power supply, insure correct polarity of wiring to avoid damage to the LED board:
Red = +, Black = -
- EssentialLEDs must be installed only in locations that conform with the stated IP rating and within the Operating Ambient Temperature range of -22° to 122° F [-30° to 50° C]. EssentialLEDs linear products are intended for interior, dry or damp locations only.
- Due to the highly customizable nature of EssentialLEDs Linear products and the wide variety of mounting options, many variables will be encountered during product installation. Instructions provided here are general; please consult plans for your specific installation for additional instructions.

Mounting Options

For all mounting options, refer to your specific installation plans for placement. Mark mounting surfaces as appropriate, and insure that mounting surface is clean and dry.

Factory Installed Options:

1. Inside Mount End Caps – 2 Sizes for 1R and 2RL Extrusions

Inside Mount End Caps are factory-installed onto both ends of an EssentialLEDs extrusion. They allow the extrusion to be mounted by the ends only inside cabinets or shelf units.

**Inside Mount End Caps
are factory installed.**

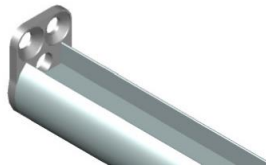

1. Hold fixture in place and mark desired placement.
2. Pre-drill mounting holes on both sides of cabinet/shelf unit.
3. Drill feeder hole for wiring according to installation plans.
4. Feed wire through feeder hole before attaching end caps to mounting surface, using screws provided.

Feed wiring to driver according to installation plans; when determining placement of driver, avoid strain on fixture wiring.

2. Bushings - 2 Sizes for 1R and 2RL Extrusions

Factory installed Bushings allow length of EssentialLEDs to be mounted perpendicular to mounting surface.

**Bushings for vertical-mount
applications are factory installed.**



1. Holes should be pre-drilled according to installation plans, using appropriate cut-out dimension
2. Cut out dimensions: 1R extrusion = 3/4" [19.05mm] diameter; 2RL extrusion = 7/8" [22.22mm] diameter.

2. Feed fixture wiring through drilled hole and secure bushing from below using nut provided.
3. Use set screw on bushing to secure fixture in desired direction. Where underside of mounting surface cannot be accessed to attach nut, bushing can be glued into place.

Feed wiring to driver according to installation plans; when determining placement of driver, avoid strain on fixture wiring.

3. Free Standing Mount – 2RL Extrusion

Factory-installed Free Standing Mount components (extrusion, elbow joints and 8mm uprights) are shipped with wiring pre-strung through the components. Bushings are provided to attach the components to the mounting surface. To assemble fixture components insert 8mm uprights into holes on underside of elbow joints and secure with set screws.

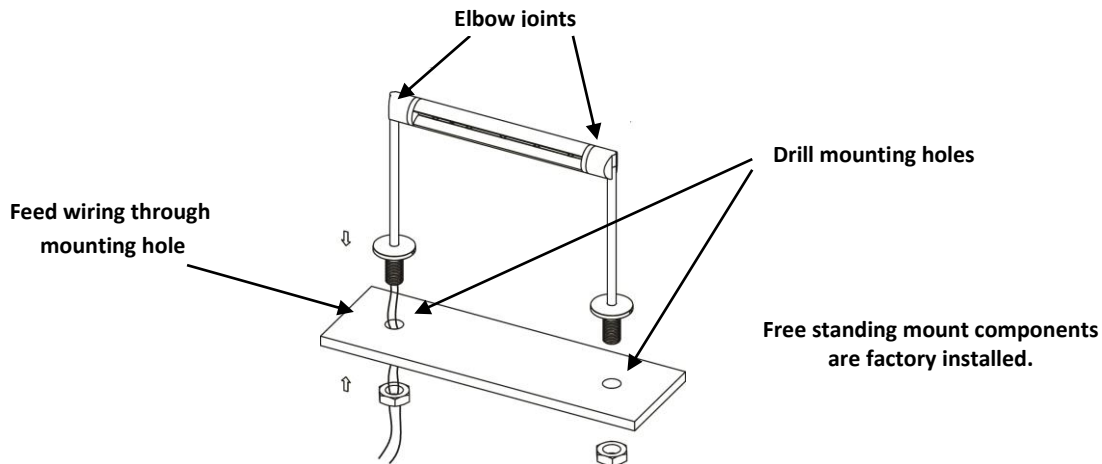

Free Standing Mount hardware allows fixture height to be adjusted from 1.25" to 19.68" (32mm to 500mm). The vertical components can recess below the mounting surface (allowing future height adjustments via set screws) or the vertical components can be cut to desired length using a tube cutter or hacksaw. Be sure to remove wiring from vertical rod before cutting; after cutting, re-string wiring through upright.

1. Drill mounting holes (3/4" [19.05mm]) as illustrated below (measure distance between 8mm uprights, center-to-center, to determine distance between holes).
2. Insert bushings in mounting holes and attach to mounting surface from below using nuts provided.
3. Feed wiring through bushing on one side (according to installation plans) then insert 8mm uprights into bushings.
4. Adjust uprights to desired height and secure with set screws.

Feed wiring to driver according to installation plans; when determining placement of driver, avoid strain on fixture wiring. To adjust direction of light output, loosen set screws on elbow joints and rotate LED bar to desired position.

Accessory Options

1. Fixed Metal Clips – 9 Sizes for 1S, 2SL, 3SL, 4SL, 7SL, 8SL, 9SL, Mini LightRun and 5SLW Extrusions

NOTE: Due to its slim form, the EssentialLEDs 1S (small square) extrusion bends easily; **CARE MUST BE TAKEN TO AVOID BENDING THE EXTRUSION DURING INSTALLATION.** Pieces of 1S extrusion over 30" in length are shipped with a support backing to prevent bending during shipment. **DURING INSTALLATION, PRODUCT MUST BE HANDLED WITH CARE!** Whenever possible, move lengths directly from support backing into clips on mounting surface.

NOTE: Due to its slim form, it is difficult **to remove** EssentialLEDs 1S (small square) extrusions from mounting clips without bending the extrusion. Before insertion into mounting clips, insure that all lengths are properly positioned in the correct location and in the correct direction. **If removal is necessary**, use a small screwdriver to pry the extrusion out of clips; **DO NOT PULL** extrusion out. Fixed Metal Clips hold square extrusions in a fixed position. Clips should be placed approximately every 12" (minimum 2 per fixture) along the length of the extrusion. Upside-down installations may require additional clips.

NOTE: When 1S extrusion uses Slide-On lensing, 2SL clip must be used.

Fixed Metal Clip
Available in 9 Sizes



1. Attached each clip to mounting surface using screws provided.
2. Gently press extrusion into clips. Allow slight separation between pieces when placing pieces end-to-end.

Feed wiring to driver according to installation plans; when determining placement of driver, avoid strain on fixture wiring.

2. Adjustable Metal Clips - 5 Sizes for 1S, 2SL, 3SL, 4SL, 7SL, 8SL & 9SL Extrusions

Adjustable Metal Clips can be bent to hold square extrusions in a fixed position at an angle to the mounting surface. Adjustable Metal Clips are intended for one-time adjustment to the desired angle; repeated adjustments will fatigue metal and could cause the clip to break.

Adjustable Metal Clip
Available in 5 Sizes



Clips should be placed approximately every 12" (minimum 2 per fixture) along the length of the extrusion. Positioning of clips will vary depending on mounting surface and desired direction; upside-down installations may require additional clips. See illustrations below for possible positions.



1. Attach clips to mounting surface using screws provided.
2. Gently press extrusion into clips.
3. Gently bend clips to adjust extrusion to the desired angle. Allow slight separation between lengths when placing pieces end-to-end.

Feed wiring to driver according to installation plans; when determining placement of driver, avoid strain on fixture wiring.

3. Adjustable Brackets – 1S, 2SL, 3SL, 4SL, 5SLW, 7SL, 8SL, 9SL; for use in combination with Fixed Metal Clips

Fixed Metal Clips can be attached to Adjustable Brackets to provide a mounting that can be angled and re-adjusted as desired. Fixed Metal Clips must be attached to Adjustable Brackets – one clip per bracket.



4. Plastic Clips - 2 Sizes for 1R and 2RL Extrusions

Plastic Clips provide an unobtrusive mounting method that raises extrusion slightly off parallel mounting surface and allows extrusion to rotate a small amount (30°) inside clip. Plastic Clips attach to the mounting surface using single screw provided; clips should be placed every 12" (minimum 2) along extrusion length. Upside-down installations may require additional clips. Extrusion snaps gently into clips. Feed wiring to driver according to installation plans; when determining placement of driver, avoid strain on fixture wiring. **Warning: Insert extrusion side-first into clip, then rotate inside clip; DO NOT FORCE CLIP OPEN to full width of extrusion!** See drawing below or refer to instructions included in Plastic Clip packaging.



Plastic Clips available in 2 sizes (1R & 2RL)

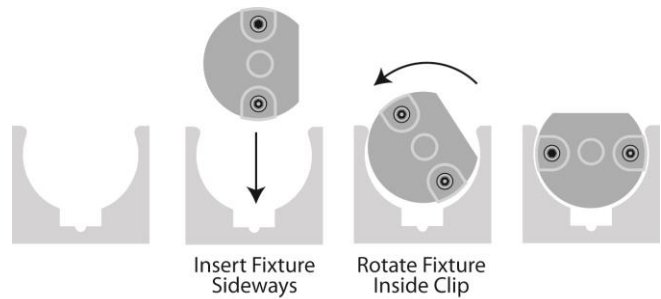

5. Locking Clips - 2 Sizes for 1R and 2RL Extrusions

Locking Clips can be used alone or in conjunction with Plastic Clips to fasten extrusion at desired angle. Locking Plastic Clips attach to the mounting surface using single screw provided; 1 locking clip per 20" (minimum 2 per fixture) if used alone, one per 3 – 4ft. when used in conjunction with Plastic Clips. Use more if secure hold is desired, i.e upside-down installation.

Locking Plastic Clips available in 2 sizes Includes set screw to fix extrusion at desired angle.



Install **Locking Clips** using screw provided. Use set screws to secure fixture at desired angle. Feed wiring to driver according to installation plans; when determining placement of driver, avoid strain on fixture wiring.

6. Metal Round Clip - 2 Sizes for 1R and 2RL Extrusions

Metal Round Clips hold round extrusions flush to a parallel mounting surface, and allow extrusion to rotate 60° inside clip. Metal Round Clips attach to the mounting surface using single screw provided; clips should be placed every 12" (minimum 2 per fixture) along extrusion length. Upside-down installations may require additional clips. **Warning: Insert extrusion side-first into clip, then rotate inside clip; DO NOT FORCE CLIP OPEN to full width of extrusion!** See drawing below or refer to instructions included in Metal Round Clip packaging. Feed wiring to driver according to installation plans; when determining placement of driver, avoid strain on fixture wiring.



Metal Clips available in 2 sizes

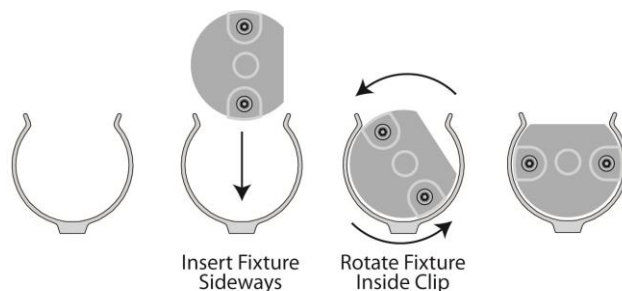

7. Adjustable Inside Mount Ring - 2 Sizes for 1R and 2RL Extrusions

Adjustable Inside Mount Rings attach to mounting surface at either end of extrusion and allow extrusion to rotate 100° inside ring.

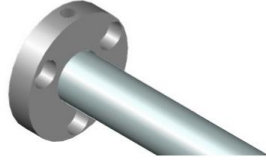

1. Use ring as template at desired position on mounting surface; mark desired mounting location on each side.
2. Pre-drill wiring hole according to installation plans.
3. Attach first ring in marked position on **wired** side, using screws provided; feed wiring through pre-drilled hole.
4. Holding the second ring on the opposite end of fixture, insert the wired end into mounted ring and adjust bar into place.
5. Rotate fixture to approximate direction desired and screw second ring into place.
6. Adjust fixture direction and lock in place using 4-40 set screws on rings.

Feed wiring to driver according to installation plans; when determining placement of driver, avoid strain on fixture wiring. Use set screws on rings to secure LED bar at desired angle.

8. Quarter Round – The Quarter Round extrusion has a self-mounting flange that is scored to allow easy drilling of mounting holes. Holes should be spaced every 12”, minimum 2 per fixture, in correct size to accommodate screws provided by others.



9. Wall or Ceiling Rough-in Kit – 3SL Extrusion

See “**Installation Instructions – Wall or Ceiling Mounting Kit**” for detailed instructions on installation of 3SL extrusion in wall or ceiling surfaces.

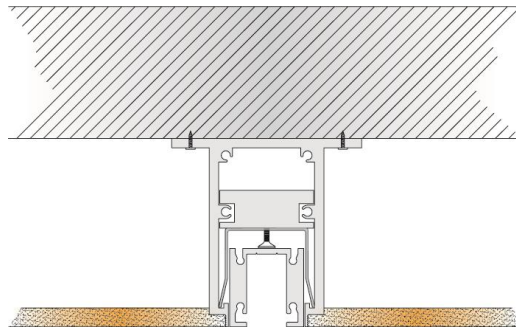

Wiring

Standard termination is 8ft. wire length (one pair, with male Tyco Mate ‘n Lock connector; connector can be removed for hard wired installations. Wire exit for each fixture is located according to project specifications.

Two-foot and 8-foot starter cables are available for connection to driver leads. Four-way and 8-way splitters are available for connecting multiple fixtures to one driver. Placement of the drivers, and the routing of wires to the drivers, will vary from project to project. In some applications, conduit may be needed to provide a wiring chase, or wires may be routed through plenum areas. For more detailed instructions, please consult NEC codes and/or the plans for your specific installation.

Wiring Guidelines

Standard circuit diagrams for wiring EssentialLED linear products are provided below. Circuit Diagrams illustrate correct wiring schematics for a Single Branch Configuration without Dimmer, Multiple Branch Configuration without Dimmer, and Multiple Branch Configuration with Dimmer. (Dimmers sold separately)

		Catalog #	Page #	Wattage	Output Voltage/Current
CONSTANT VOLTAGE DRIVERS	VLT HMLD with Enclosure	HMLD - 48	120	48w	24v
		HMLD - 96	120	96w	24v
		HMLD - 288	120	3 x 96w	24v
	VLT HELD w/ Enclosure	HELD - 48 - 24DC	121	48w	24v
		HELD - 96 - 24DC	121	96w	24v
		HELD - 288 - 24DC	121	288w	24v
	VLT HELD DMX Dimming Module w/ Enclosure	HELD - DMX(x) - 48 - 24DC	122	48w	24v
		HELD - DMX(x) - 72 - 24DC	122	72w	24v
		HELD - DMX(x) - 96 - 24DC	122	96w	24v
	VLT HELD DALI Dimming Module w/ Enclosure	HELD - DALI(x) - 48 - 24DC	123	48w	24v
		HELD - DALI(x) - 72 - 24DC	123	72w	24v
		HELD - DALI(x) - 96 - 24DC	123	96w	24v
	VLT HELD 0-10v Dimming Module w/Enclosure	HELD - 010 - 48 - 24DC	124	48w	24v
		HELD - 010 - 72 - 24DC	124	72w	24v
		HELD - 010 - 96 - 24DC	124	96w	24v
	Lutron	L3DA4U1UKL-CV240	125	40w	24v
		LTEA4U1UKL-CV24Q	125	40w	24v
		L3D0 - 96W - 24V - U	125	96w	24v
	MEAN WELL CLASS 2	HLG - 40H	126	40w	24v
		HLG - 80H	126	80w	24v
		HLG - 100H	126	100w	24v
	MEAN WELL CLASS 2 Plastic Case	LPF - 16	127	16w	24v
		LPF - 25	127	25w	24v
		LPF - 40	127	40w	24v
		LPF - 60	127	60w	24v
		LPF - 90	127	90w	24v
	Osram w/ Enclosure	OT96	128	96w	24v
OT96/DIM		128	96w /DIM	24v	
OT96/JBX		128	96w	24v	



NON-DIM (SHOWN IN SINGLE BRANCH CONFIGURATION)

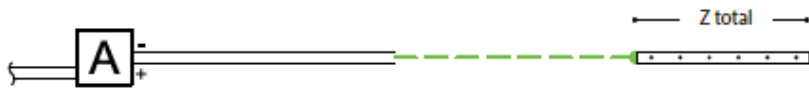

NON-DIM (SHOWN IN MULTIPLE BRANCH CONFIGURATION)

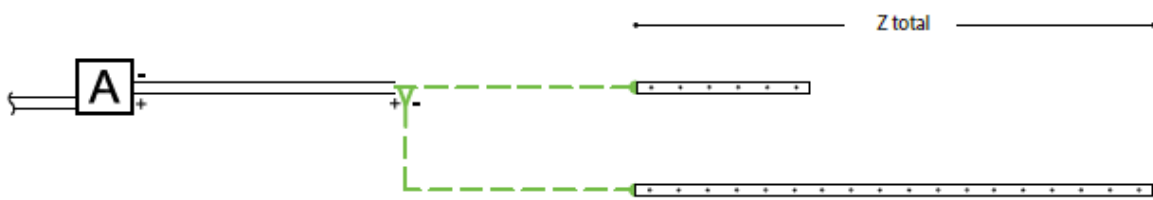

DIMMABLE with HMLD Magnetic Low-Voltage Driver (SHOWN IN MULTIPLE BRANCH CONFIGURATION)
(i.e. VLT Hybrid Magnetic Linear Dimming Drivers)

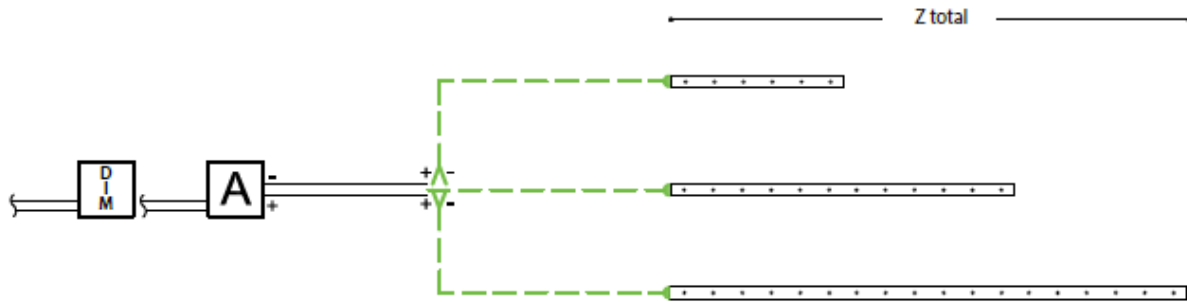

	Driver A	Total Nominal Inches of Linear Fixture "Z"															
		EFlex			Standard Boards				Hi CRI		Pitchless		Dual Row				
		Driver Load	1320	2320	4320	1720	2730	4740	5760	6760	3720	3740	3760	5133	5163	3760D	6760D
Class 2 Drivers	40w	240"	180"	92"	240"	149"	116"	88"	66"	240"	123"	83"	130"	65"	41"	33"	
	48w	288"	216"	110"	288"	178"	140"	105"	80"	288"	148"	99"	157"	78"	49"	40"	
	72w	432"	324"	165"	432"	268"	210"	158"	119"	432"	222"	149"	235"	117"	74"	59"	
	96w	576"	432"	220"	576"	357"	280"	211"	159"	576"	296"	199"	314"	157"	99"	80"	

1. Figure for inches of linear fixture per driver was calculated using a 90% load capacity for each wattage driver; drivers can be loaded higher - contact factory for advice. Some drivers require 50% minimum load for proper dimming. 2. Dimming performance will be impacted by type of driver, type of dimming, driver load and dimming control equipment; results will vary based on components used. 3. To determine correct wire gauge for your application, please refer to the voltage drop calculator on the VLT website (see Downloads tab in Drivers & Controls section). For constant voltage fixtures, VLT recommends a drop of no greater than one volt from driver to fixture.

SYMBOLS

- 24V Driver
- Magnetic Low-Voltage Dimmer

WIRING

- Line Voltage Input
- Starter / Interconnect / Splitter
- Fixture Lead Wire 24v - (2) 18AWG
- Essential LEDs® Linear Fixture or Mini Light Run

Wiring Diagram & Notes:

- AC-PWR-DIM may be controlled by 1-10V DC controllers, 1-10V converters, or 100 k Ohm linear potentiometers.
- AC-PWR-DIM has two dependant channel outputs (internally, these channels are in parallel). The sum of the loads from the channel outputs must not exceed the maximum output of the OTDIM (52.2W at 10V and 120W at 24V).

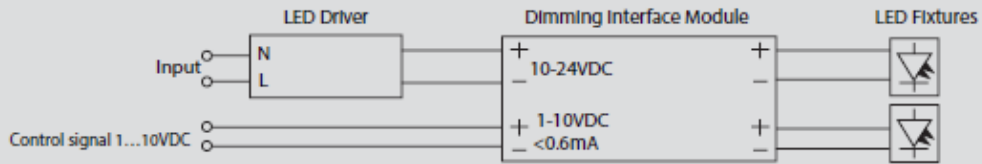

DIMMABLE (SHOWN IN MULTIPLE BRANCH CONFIGURATION)

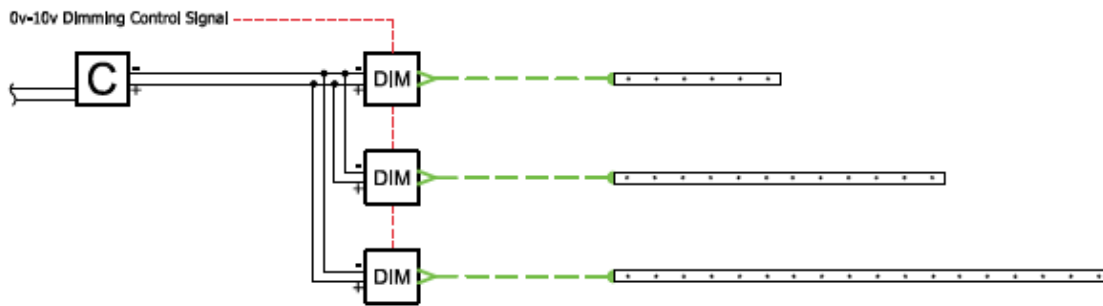

DIMMABLE (SHOWN IN MULTIPLE BRANCH CONFIGURATION)

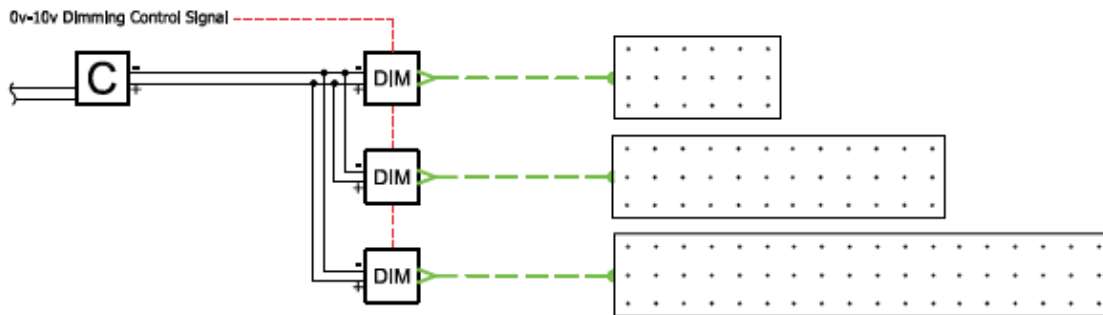

1. Fixture was calculated using a 90% load capacity for each wattage driver; drivers can be loaded higher - contact factory for advice. Some drivers require 50% minimum load for proper dimming. 2. Dimming performance will be impacted by type of driver, type of dimming, driver load and dimming control equipment; results will vary based on components used. 3. To determine correct wire gauge for your application, please refer to the voltage drop calculator on the VLT website (see Downloads tab in Drivers & Controls section). **For constant voltage fixtures, VLT recommends a drop of no greater than one volt from driver to fixtures.**

SYMBOLS

- 96w 24v Driver
100-277v 50/60hz
- 0-10v Dimmer

WIRING

- Line Voltage Input
- Starter / Interconnect / Splitter
- Fixture Lead Wire 24v - (2) 18AWG
- Essential LEDs* Linear Fixture
- Essential LEDs* Light Panel ELP-L

Cleaning

To clean **LENSED** EssentialLEDs linear products, wipe all surfaces with a soft damp cloth. **DO NOT** use solvents or other harsh chemicals. **DO NOT** use excessive water or cleaning products on lensed products.

For EssentialLEDs products **WITHOUT LENSES** (1S and 1R extrusions), a compressed-air spray product can be used to remove dust from the LED board. **DO NOT** use water on or near non-lensed products.

EssentialLEDs Linear fixtures have no user serviceable parts; when not in use, EssentialLEDs Linear fixtures and system driver components should be stored in a cool, dry location.

SAFETY INSTRUCTIONS

READ ALL INSTRUCTIONS BEFORE USING

When using an electrical furnishing, basic precautions should always be followed, including the following:

WARNING – To reduce the risk of burns, fire, electric shock, or injury to persons:

1. Unplug from outlet before putting on or taking off parts.
2. Close supervision is necessary when this furnishing is used by, or near children, invalids, or disabled persons.
3. Use this furnishing only for its intended use as described in these instructions. Do not use attachments not recommended by the manufacturer.
4. Never operate this furnishing if it has a damaged cord or plug, if it is not working properly, if it has been dropped or damaged, or dropped into water. Return the furnishing to a service center for examination and repair.
5. **Keep electrical cord(s) away from heated surfaces and control cord(s) to avoid tripping hazards.**
6. Never operate the furnishing with the air openings blocked. Keep the air openings free of lint, hair, and the like.
7. Never drop or insert any object into any opening.
8. Do not use outdoors.
9. Do not operate where aerosol (spray) products are being used or where oxygen is being administered.
10. To disconnect, turn all controls to the off position, then remove plug from outlet.
11. For loading always put heavier items at the bottom and not near the top in order to help prevent the possibility of the furnishing tipping over.

WARNING: Risk of Electric Shock – Connect this furnishing to a properly grounded outlet only. See Grounding Instructions.

GROUNDING INSTRUCTIONS FOR ALL GROUNDED, CORD-CONNECTED PRODUCTS:

This product must be grounded. If it should malfunction or breakdown, grounding provides a path of least resistance for electric current to reduce the risk of electric shock. This product is equipped with a cord having an equipment-grounding conductor and a grounding plug. The plug must be plugged into an appropriate outlet that is properly installed and grounded in accordance with all local codes and ordinances.

DANGER – Improper connection of the equipment-grounding conductor can result in a risk of electric shock. Check with a qualified electrician or serviceman if you are in doubt as to whether the product is properly grounded. Do not modify the plug provided with the product – if it will not fit the outlet, have a proper outlet installed by a qualified electrician.

This product is for use on a nominal 120-volt circuit and has a grounding plug. Make sure that the product is connected to an outlet having the same configuration as the plug. No adapter should be used with this product.

GROUNDING INSTRUCTIONS FOR A PERMANENTLY CONNECTED PRODUCT:

This product must be connected to a grounded metal, permanent wiring system, or an equipment-grounding conductor must be run with the circuit conductors and connected to the equipment-grounding terminal or lead on the product.